

**SM1.10(S) / SM1.12(S)**  
Modulating Actuators AC/DC 24 V - Speed Version

**Application**

The **JOVENTA SPECIAL** electric damper actuator series is designed to operate air dampers in ventilation and air conditioning systems. The compact design and universal adapter fitted with limitation of rotation angle make this JOVENTA actuator highly versatile.

**Features**

- DC 0(2)...10 V or 0(4)...20 mA control signal
- Working area adjustable
- Load-independent running time
- Up to 5 actuators in parallel operation possible
- Plug-in terminal block connection
- Simple direct-mount with universal adapter on 10...20 mm Ø round-axis or 10...16 mm square shaft
- 48 mm minimum damper shaft length
- Selectable direction of rotation
- Limitation of rotation angle
- Manual release button
- 2 adjustable auxiliary switches
- Automatic shut-off at end position (overload switch)
- Actuators available with 1 m cable
- Customized versions available

**Accessories**

- ZK Damper linkage selection
- ZKG Ball joints

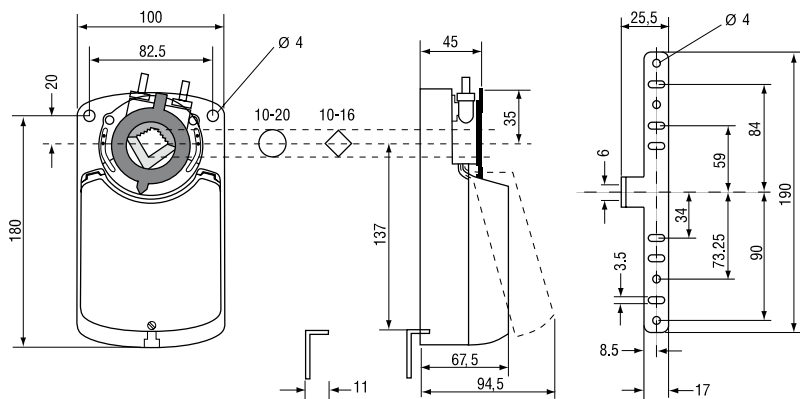

Dimensions in mm

**Ordering Codes**

Codes	Descriptions
<b>SM1.10</b>	AC/DC 24 V
<b>SM1.10(S)</b>	AC/DC 24 V, with 2 auxiliary switches
<b>SM1.12</b>	AC/DC 24 V
<b>SM1.12(S)</b>	AC/DC 24 V, with 2 auxiliary switches

**SM1.10(S) / SM1.12(S)**  
Modulating Actuators AC/DC 24 V - Speed Version

**Wiring Diagram**

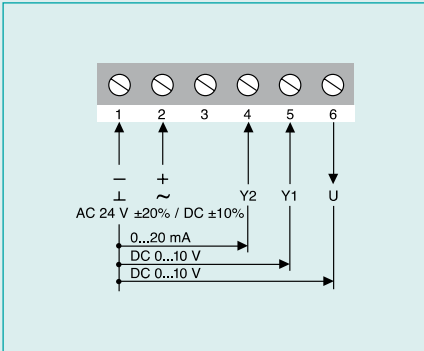

**Parallel Connections**

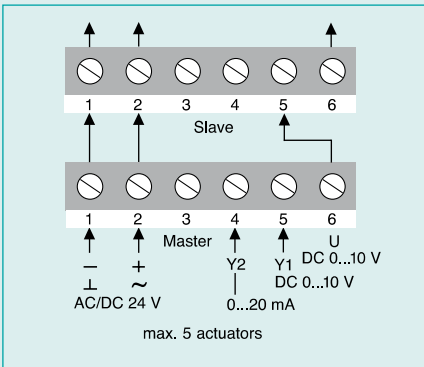

**Position transmitter**

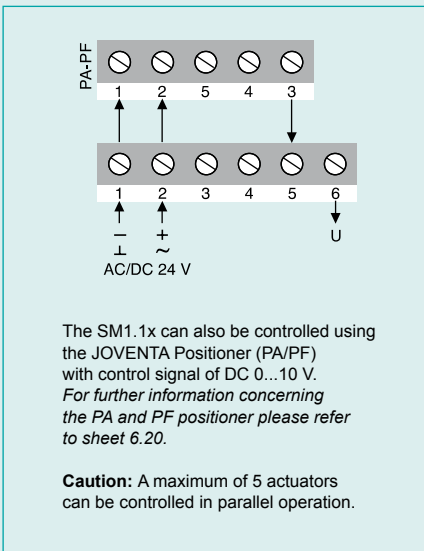

**Setting the control Signal**

Control signal Y1 DC 0...10 V  
Input resistance Ri 250 kΩ

Control signal Y2 0...20 mA  
Input resistance Ri 388 Ω

Position signal U DC 0...10 V  
Load resistance > 50 kΩ

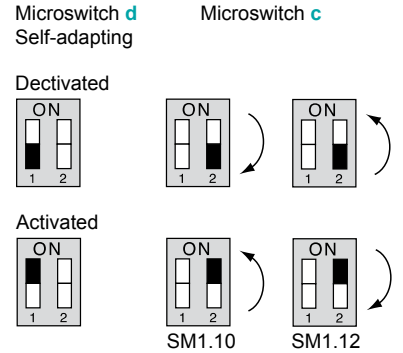

By switching microswitch **d** to ON position, the control signal Y1 or Y2 will be adapted to the chosen angle of rotation.

By switching microswitch **c** the direction of rotation can be changed.

**Setting Span and OFFSET**

The potentiometers **O** and **S** help to match control signals Y1 and Y2 to any make of controller.

**Example 1**

Control signal Y1 working between DC 2...10 V  
Setting: Starting point **O** = 2  
working range **S** = 8

**Example 2**

Control signal Y2 working between 6...18 mA  
Setting: Starting point **O** = 3  
Working range **S** = 6

**Start point O**

	<b>Scale O</b>	<b>0</b>	<b>1</b>	<b>2</b>	<b>3</b>	<b>4</b>	<b>5</b>	<b>6</b>	<b>7</b>	<b>8</b>
	for Y1 (VDC)	0	1	2	3	4	5	6	7	8
	for Y2 (mA)	0	2	4	6	8	10	12	14	16

**Working range S**

	<b>Scale S</b>	<b>2</b>	<b>3</b>	<b>4</b>	<b>5</b>	<b>6</b>	<b>7</b>	<b>8</b>	<b>9</b>	<b>10</b>
	for Y1 (VDC)	2	3	4	5	6	7	8	9	10
	for Y2 (mA)	4	6	8	10	12	14	16	18	20

**SM1.10(S) / SM1.12(S)**  
Modulating Actuators AC/DC 24 V - Speed Version

**Auxiliary Switches (S)**

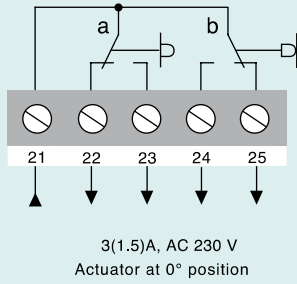

**Override Control**

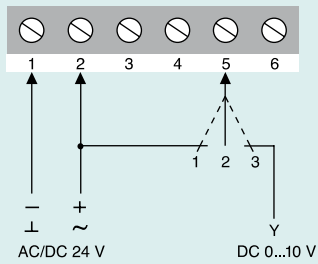

The actuator SM1.1x can be forced to override control when wired in accordance with the diagram.

- Switch position:
- 1 = Actuator runs at 10 V
  - 2 = Actuator runs at 0(2) V
  - 3 = Automatic control

**Settings the auxiliary switches**

Factory setting  
Switch **a** at 10°  
Switch **b** at 80°

The switching position can be manually changed to any required position by turning the ratchet

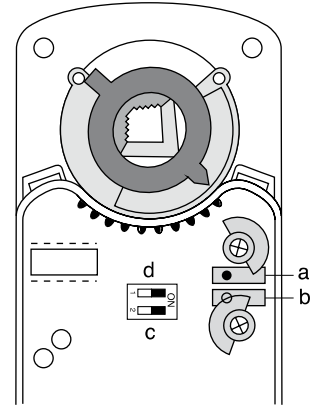

**Limitation of Rotation Angle**

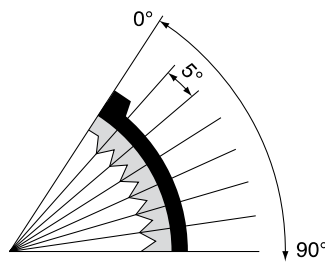

The limitation or rotation angle can be set in 5° steps by moving the adapter.

**Adapter release**

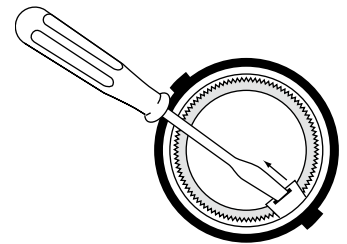

The adapter can be removed simply by pressing the adapter clip on the underside of the actuator

**SM1.10(S) / SM1.12(S)**  
**Modulating Actuators AC/DC 24 V - Speed Version**
**Technical Specifications**

Actuator	SM1.12(S)	SM1.10(S)
Torque	8 Nm	16 Nm
Damper area*	1.5 m <sup>2</sup>	3.0 m <sup>2</sup>
Running Time OPEN	8 s	16 s
Running Time CLOSE	8 s	16 s
Supply Voltage	AC/DC 24 V	
Frequency	50-60 Hz	
Power Consumption		
- Running	6.0 W	
- At end position	0.6 W	
Dimensioning	15.0 VA / 3.6 A @ 2 ms	
Working area Y	not adjustable	
Control Signal Y1	DC 0(2)... 10 V	
Input resistance Y1	Ri 250 Ω	
Control Signal Y2	0(4)...20 mA	
Input resistance Y2	Ri 388 Ω	
Position signal U	DC 0...10 V	
Load resistance	> 50 kΩ	
Angle of rotation / Working range	90° (93° mech.)	
Angle of rotation/Limitation	5°...85° in 5° < steps	
Auxiliary Switches	3(1.5) A, AC 230 V	
- S1 setting range	5°...85° < adjustable	
- S2 setting range		
Cable	1 m halogen-free	
- Motor	5-Wire 1-2-4-5-6	
- Switches	5-Wire 21-22-23-24-25	
Life time	60.000 rotations	
Noise level	45 dB (A)	
Protection Class	II	
Degree of Protection	IP 54	
Mode of Action	Type 1	
Ambient conditions		
- Operating temperature	-20...+50 °C / IEC 721-3-3	
- Storage temperature	-30...+60°C / IEC 721-3-2	
- Humidity	5...95% r.F. no condensed	
Weight	1.1 Kg	
Service	Maintenance-free	
 Conformity	<b>EMC Directive 2004/108/EC</b> <b>Low Voltage Directive 2006/95/EC</b>	

\*Caution: Please note damper manufacturer's information concerning the open/close torque.